



Cover 1:  
Napoli Tan

Optional Extra  
Scatter Cushions

Black Feet

# Warren Leather Collection



Colours represented are to be used as a guide only.  
Please refer to manufacturers swatch for a more accurate colour match.

Please note that leather colour shadings can vary slightly from batch to batch.  
We cannot guarantee a precise match to these samples or between cut lengths and upholstered goods.

27/03/2023

# WARREN LEATHER COVER GUIDE: STANDARD BACK ONLY

Please use this guide when ordering the following pieces to clarify cover options.

4 Seater Sofa (4ST)

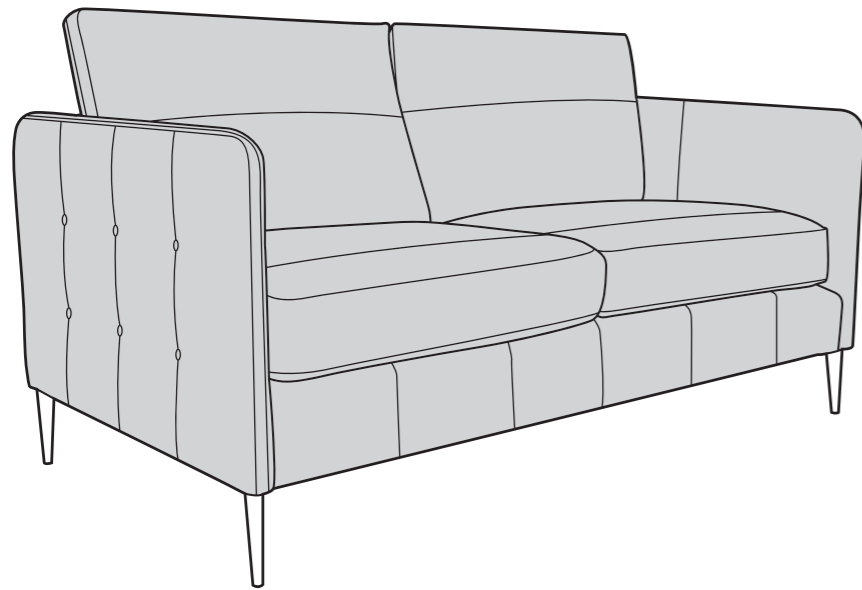

3 Seater Sofa (3ST)

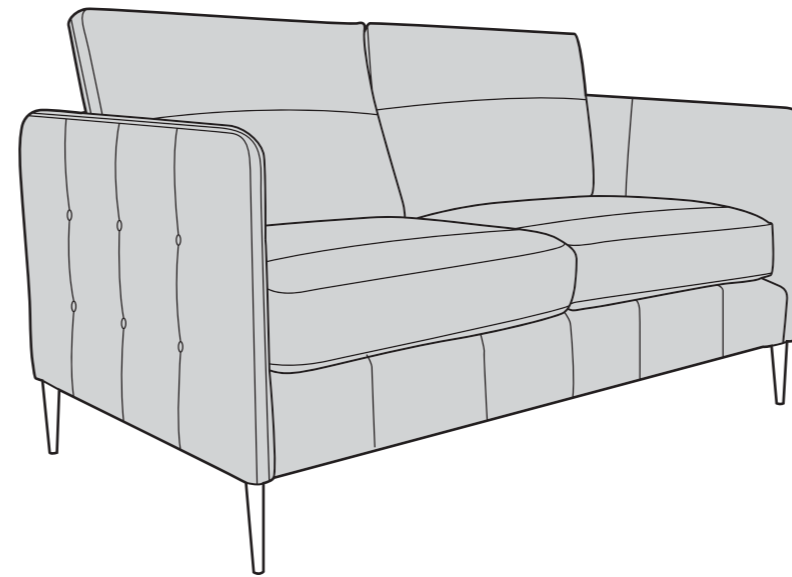

2 Seater Sofa (2ST)

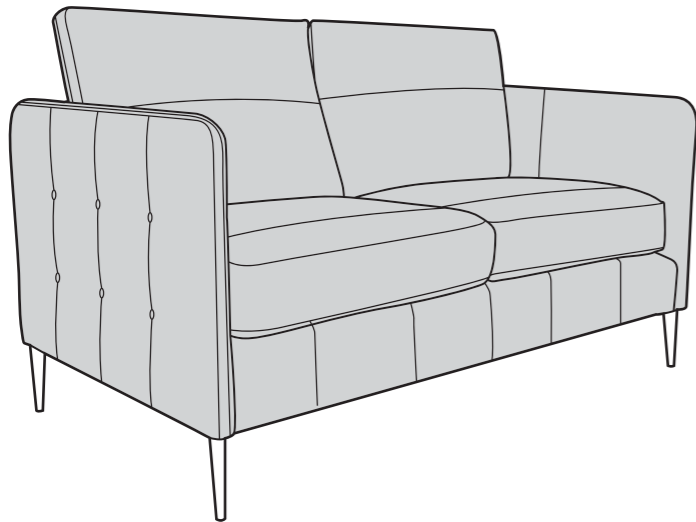

Armchair (1ST)

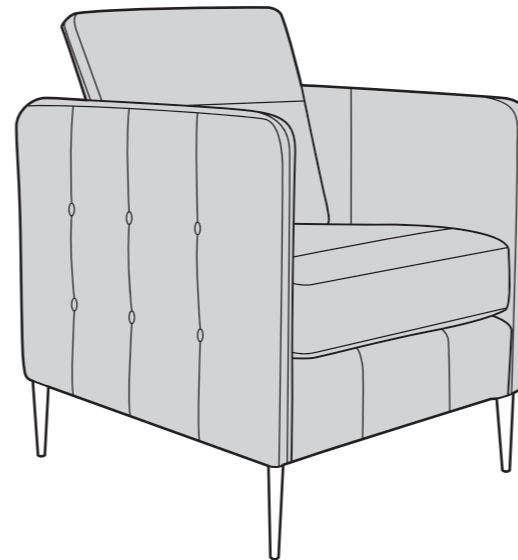

## SUGGESTED ACCENT PIECES

Warren Leather Footstool (FST)

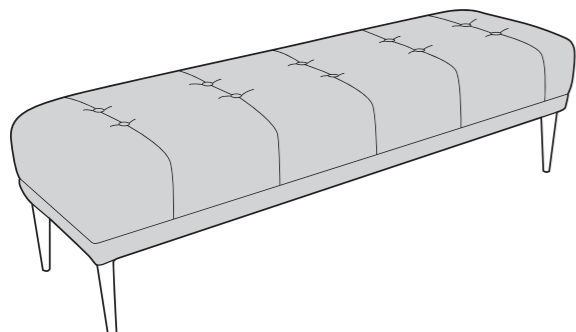

Leather Storage Footstool (FSS)

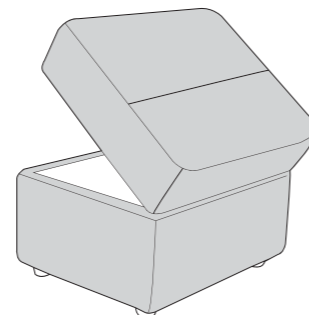

# WARREN LEATHER DIMENSIONS (CM)

| AVAILABLE PIECES                | HEIGHT 1 | WIDTH 2 | DEPTH 3 | SEAT HEIGHT 4 | SEAT DEPTH 5 | SEAT WIDTH 6 | ACCESS DIAGONAL 7 | OUTBACK HEIGHT 8 | ARM HEIGHT 9 | WEIGHT (KG) |
|---------------------------------|----------|---------|---------|---------------|--------------|--------------|-------------------|------------------|--------------|-------------|
| 4 SEATER SOFA (4ST)             | 90       | 198     | 98      | 53            | 58           | 177          | 216               | 75.5             | 77           | 60          |
| 3 SEATER SOFA (3ST)             | 90       | 170     | 98      | 53            | 58           | 149          | 190               | 75.5             | 77           | 54.5        |
| 2 SEATER SOFA (2ST)             | 90       | 149     | 98      | 53            | 58           | 128          | 170               | 75.5             | 77           | 50          |
| ARMCHAIR (1ST)                  | 90       | 84      | 98      | 53            | 58           | 63           | 120               | 75.5             | 77           | 38.5        |
| <b>ACCENT PIECE</b>             |          |         |         |               |              |              |                   |                  |              |             |
| WARREN LEATHER FOOTSTOOL (FST)  | 39       | 135     | 39      | N/A           | N/A          | N/A          | 137               | N/A              | N/A          | 15          |
| LEATHER STORAGE FOOTSTOOL (FSS) | 45       | 63      | 50      | N/A           | N/A          | N/A          | 75                | N/A              | N/A          | 12.5        |

- \* Hardwood & composite board frame.
- \* Dowelled, screwed, glued & stapled joinery.
- \* A choice of Black, Gold or Chrome Metal Foot or a Wood selection in Walnut or Beech

- \* Zipped in Leather backs.
- \* Ultimateflex seat cushions.

- \* Serpentine seat springs & silent wire.
- \* Elasticated back webbing.

## DIMENSION GUIDE

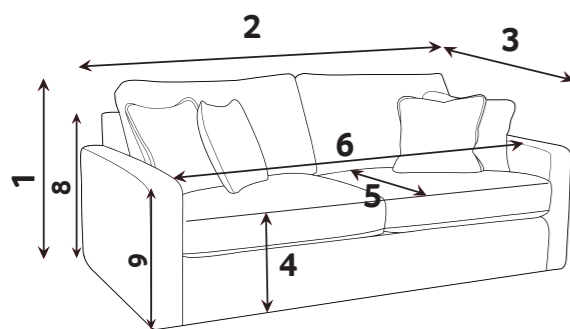

Check the diagonal access dimension to ensure furniture will fit in your home.

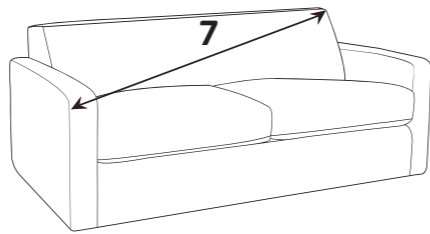

- 1 - HEIGHT
- 2 - WIDTH
- 3 - DEPTH
- 4 - SEAT HEIGHT
- 5 - SEAT DEPTH (STD & PILLOW)
- 6 - SEAT WIDTH
- 7 - DIAGONAL ACCESS
- 8 - OUTBACK HEIGHT
- 9 - ARM HEIGHT

Illustrations used for reference only.

## Ultimate-Flex

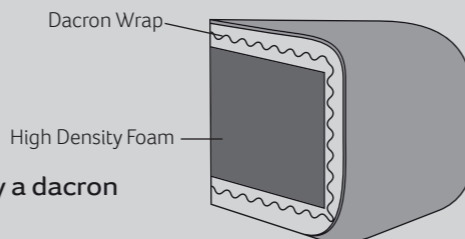

A high loft, high density foam inner seat interior surrounded by a dacron wrap that provides both comfort and support.

## CARE GUIDE

Ultimate-Flex seat cushions should be plumped up on a regular basis to help maintain the aesthetic appeal of your upholstery, the plumping of cushions is essential to help retain the comfort and softness of any piece of upholstered furniture.

For further information on maintaining your furniture please refer to the care guide located under the seat platform.

## THIS COLLECTION USES:



Kind Leather focus on creating truly sustainable leather, cutting down on wasted product and the use of harmful chemicals that can be damaging to the environment.

Some of the benefits of Kind Leather include:



Up to 62% less electrical energy consumed.



Up to 52% lower water consumption.

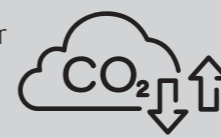

Up to 43% lower global warming potential.



Up to 40% less chemicals consumed.

## FOOT OPTIONS:

Black



Gold



Chrome



Walnut



Beech



Please note: All dimension are approximate. Allow tolerance of +/- 2.5cm.

Wood is a natural product and will vary in shade/colour from item to item. Feet may require fitting.



27/03/2023

# LEATHER RANGE

We only use full leather for our collections; no splits apply.



## VERONA

Verona is a Pigmented leather made of top quality heavy-weight hides processed in Italy. The higher-thickness enhances the hand-feel and the visual opulence of the leather. Hides are machine-buffed to remove superficial characteristics before being coated with a pigment to ensure colour consistency. Following this, hides are embossed with an artificial grain to give a uniform appearance and further reduce any visible traces of natural markings. These additional treatments only increase the product's physical durability, reduce absorption from spills, and is a family-friendly option for those seeking to get the most out of leather's hard-wearing properties.



## NAPOLI

Napoli is a natural grain, Semi-Aniline leather made of high quality hides that have been processed in Italy. A special re-tanning process is applied to give the leather its rich hand feel. A contrasting roller effect has been applied to the surface of each hide to add visual character, before being treated with a protective finish to increase durability. A characterful and family-friendly leather.



## TURINO

Turino is lightly-buffed, two-tone natural grain Semi-Aniline leather made of top quality hides that have been processed in Italy. Hides are then finished with a pigment to increase top-coat durability, before a very subtle darker contrasting effect is applied to the tips of the grain to create a discreet two-tone affect. A family friendly leather with a wide appeal.



## CAPRI

Capri is a hand-buffed Aniline leather made of top quality hides that have been processed in Italy. This leather is a celebration of the rich history of each and every hide and the individual characteristics that make them unique. The hides are buffed by hand, piece by piece. Other than a light protective finish that has been applied to the grain in order to increase its physical performance, Capri's surface is completely natural and free from additional treatments so as to retain the natural look of the leather. Natural leather will be subject to shade variation between and even within upholstered panels, ensuring every piece of furniture is unique.



## LAZIO

Lazio is a hand-buffed Aniline leather made of top quality hides that have been processed in Italy. This leather is a celebration of the rich history of each and every hide and the individual characteristics that make them unique. The hides are buffed by hand, piece by piece. Other than a light protective finish that has been applied to the grain in order to increase its physical performance, Lazio's surface is completely natural and free from additional treatments so as to retain the natural look of the leather. Natural leather will be subject to shade variation between and even within upholstered panels, ensuring every piece of furniture is unique.

